

NOTE: FOR SPECIFIC PIPE SIZE AND LOCATION, SEE JOB DETAILS
SEE FOUNDATION DETAILS FOR CONSTRUCTION.
FOR SUMP DIMENSIONS, SEE 3520.

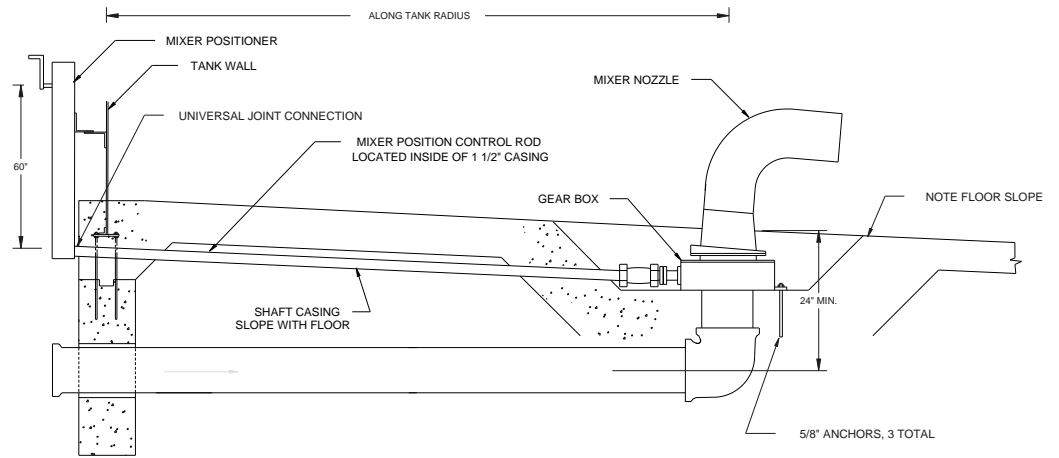

PIPE CONNECTION AT GEAR BOX IS 6", REDUCER OR REDUCING ELBOW MAY BE REQUIRED.

MIXER POSITIONER SEE DRW. 3555

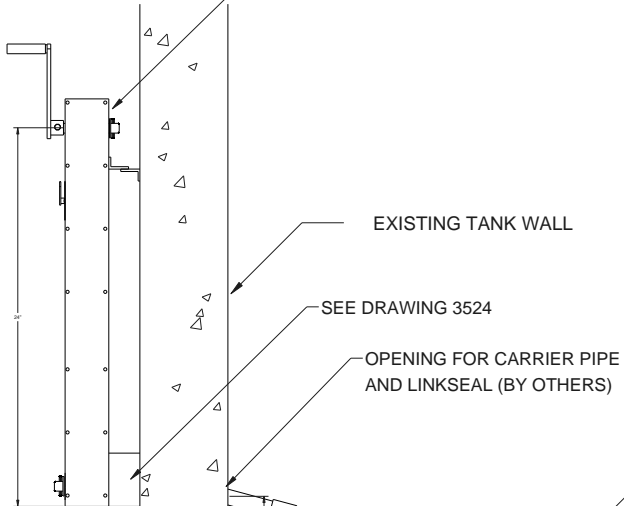

MIXER POSITION CONTROL ROD

PIPE SUPPORT AS REQUIRED BY OTHERS

FIELD VERIFY

NOTE: "PIPING PROVIDED BY OTHERS"
SEE CONTRACT DRAWINGS.

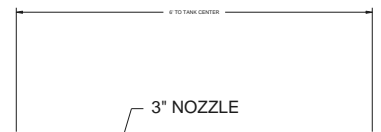

SEE DRAWING 3521

EL. TO BE FIELD DETERMINED
TO ACCOMMODATE PIPING

8" FLANGED BASE ELBOW
ROTATED AS REQUIRED

5/8"x 6" 304 SS MOUNTING BOLTS